

FULL OVERLAY 110° -- EN APPLIQUÉE 110°

H = Height of plate -- Hauteur de plaque

A = Minimum gap -- Distance Minimum

K = Cup drilling distance -- Distance de perçage du boîtier

T = Door thickness -- Épaisseur de la porte

S = Side gable thickness -- Épaisseur du côté

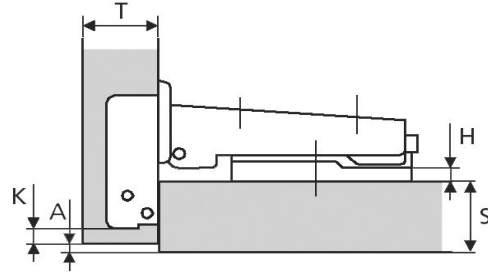

$$H = (14 + A + K) - S$$

	T =	16	17	18	19	20	21	22	23	24	25	26
K = 3	A =	0.57	0.74	1.11	1.45	1.81	2.38	3.10	3.92	4.71	6.69	6.51
K = 4	A =	0.55	0.72	1.05	1.39	1.75	2.25	2.87	3.60	4.36	5.73	6.03
K = 5	A =	0.53	0.70	0.99	1.33	1.67	2.12	2.64	3.28	4.01	4.77	5.55
K = 6	A =	0.51	0.69	0.93	1.27	1.61	1.99	2.49	3.05	3.69	4.41	5.18
K = 7	A =	0.50	0.67	0.87	1.21	1.55	1.89	2.35	2.85	3.46	4.10	4.82

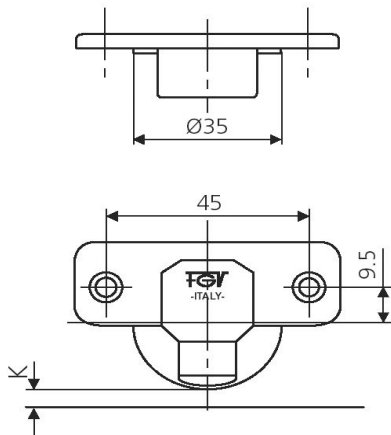

Cup fixed with wood screws
Fixation du boîtier à l'aide de vis à bois

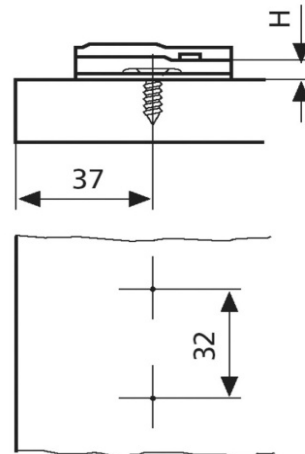

Mounting plate fixed with wood screws
Plaque de montage à l'aide de vis à bois

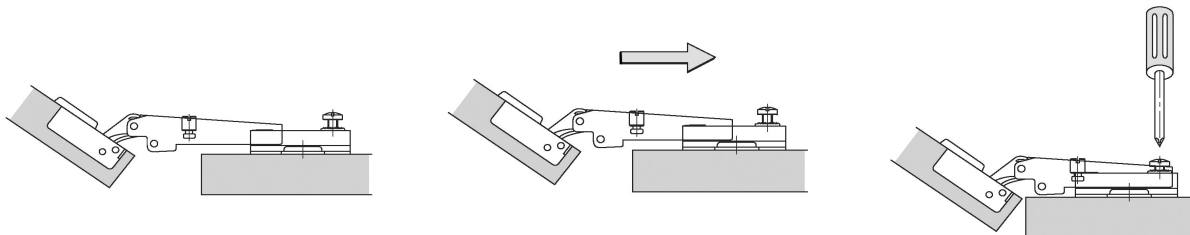

Place the rear part of the hinge on the front side of the mounting plate.

Aligner la partie arrière de la charnière avec le devant de la plaque de montage.

Let the hinge slide on the plate including the pin and until it stops.

Faire glisser la charnière sur la plaque jusqu'à la vis.

Tighten the connecting screw

Serrer la vis d'assemblage